

ProLine wall mounting cabinets

1. GENERAL CHARACTERISTICS

The ProLine wall mounting rack cabinets is used in the offices for limited U height is required. ProLine 19" cabinets are metal and provide IP20 protection.

The main parts of ProLine 19" free standing cabinets are;

- Two 19" adjustable mounting angles in depth.(If needed 2 additional mounting angles could be ordered as accessory)
- Front door with glass door, perforated metal door options.
- Removable and lockable 2 side panels.
- Metal rear panel
- Load carrying capacity is 50 kg if used as a wall mounting cabinet.
- Load carrying capacity is 200 kg if used as a free standing cabinet*.
- Standard colour options are RAL 9003 signal white, RAL 9005 black

Structure; Without having uprights ProLine has loading capacity of 50 kg. Moreover, it allow users a perfect reachness and intervention to devices and cables. Single opening front door with opening angle more than 180 degree gives flexibility to consumers. In addition, ProLine series could be used as a free standing cabinet with leveling feet and castors. Vented top cover provides passive heat transportation via convection. There is a single vented fan hole suitable for fan for optimum cooling. Two 19" adjustable mounting angles could be moved 125mm together on rails.

Door; features a full-length smoked and shatterproof glass door. It is lockable and removable. Also, the door hinge is easily swapped from one side to the other to change the direction of the door opening.

Side Panels; are removable, lockable, complete without a lock. Thus, possible to easy access to equipment and gives better look and improved security

Back Panel; could be removable and be mountable on the wall easily.

Cable Entries; Bottom chassis; 1, microjoint
Top chassis; 1, microjoint
Back panel; 1, microjoint

There is one sliding cable entry part in every ProLine cabinet. Thus, you may break one of the microjoint part (excluding the one on the back panel) and may mount that part.

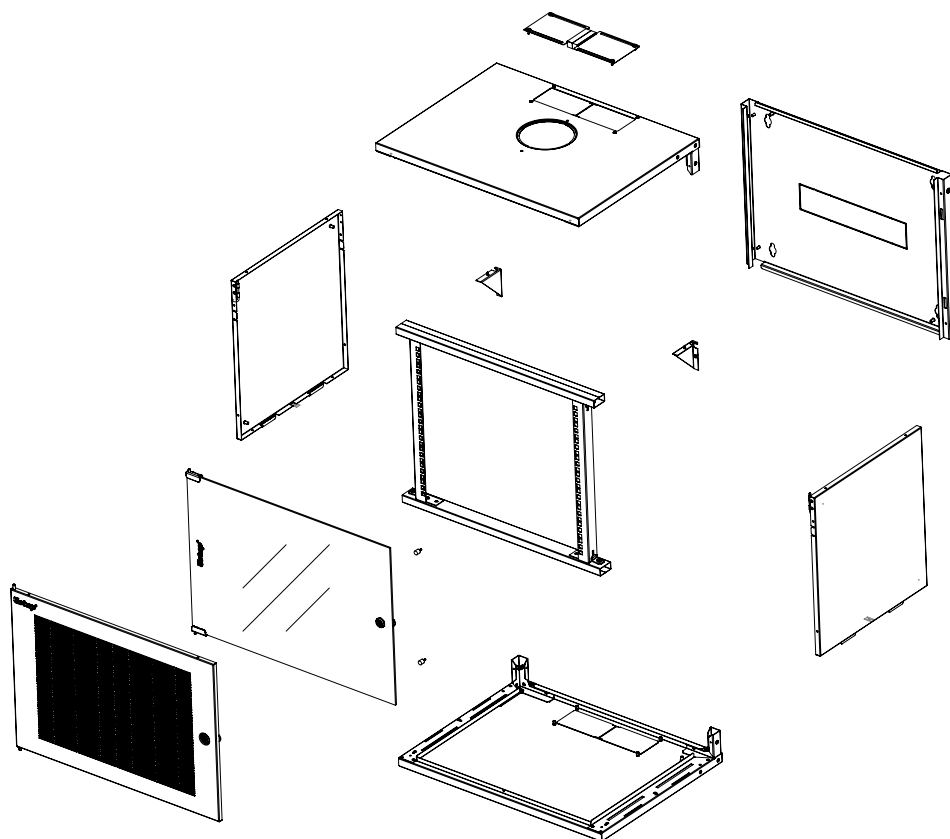

Exploded view

* If, 4 pieces of 19" mounting angles and 4 point fixing shelf used together it can carry up to 200 kg.

ProLine wall mounting cabinets

2. TECHNICAL CHARACTERISTICS

2.1. INDEX OF PROTECTION

- IP20 according to EN61587-1, IEC60529
IP20: Protected against solid objects larger than 12,5 mm in diameter

2.2. MECHANICAL PERFORMANCE

- Permissible load:
Wall mounted: 50 kg
Free standing: 200kg*

2.3 DESIGN

- Non upright structure
- Mounting angles, top and bottom base units are solid metal with 1,5 mm thickness
- Top and bottom chassis are solid metal with 1,5 mm thickness
- Side panels made of 0,8 mm thick sheet steel.
- Front door, shatterproof glass with left and right frame
- Front door opening angle is 180 degree
- Glass, 4 mm thickness full-length smoked, shatterproof, tempered, secure
- Cabinet standard colours RAL 9003 signal white and RAL 9005 black

2.4. CORROSION RESISTANCE

- ISO9227 and ASTM B 117-85

2.5. PROPERTIES OF THE PAINTING COATING

- Excellent impact and scratch resistance
- Excellent resistance to cleaning agents (excluding strong chlorinated, fluorinated and ketone solvents) Some products may change appearance, It is therefore advisable to carry out a test first.

3. STANDARDS

- ISO 9001: 2008 Quality Management Systems
- ISO 14001: 2004 Environmental Management System
- 19" mounting to IEC 297-1
- EN 61587-1 mechanical structures (cabinets for electronic equipment)
- Overall cabinet dimensions for IEC 297-2

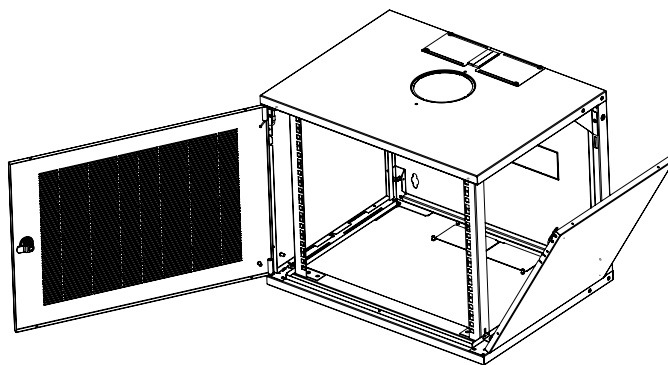
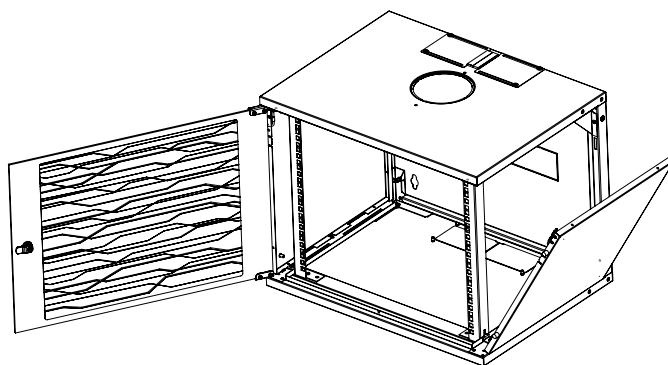

ISO view

* If, 4 pieces of 19" mounting angles and 4 point fixing shelf used together it can carry up to 200 kg.

ProLine wall mounting cabinets

4. DIMENSIONS

PART NUMBER	U Height	W	D	H	Depth (with 4 Mounting Angles): Max. Mounting (mm)	Depth (with 4 Mounting Angles): Min. Mounting (mm)	Height: Max. Mounting (mm)	Height: with Leveling Feet (mm)	Height: without Leveling Feet (mm)	Height: with Casters (mm)
PR06U6045	06U	600	450	342	339	89	277	367	342	412
PR07U6045	07U	600	450	387	339	89	322	412	387	457
PR09U6045	09U	600	450	476	339	89	411	501	476	546
PR12U6045	12U	600	450	609	339	89	544	634	609	679
PR16U6045	16U	600	450	787	339	89	722	812	787	857
PR20U6045	20U	600	450	965	339	89	900	990	965	1035
PR06U6060	06U	600	600	342	489	239	277	367	342	412
PR07U6060	07U	600	600	387	489	239	322	412	387	457
PR09U6060	09U	600	600	476	489	239	411	501	476	546
PR12U6060	12U	600	600	609	489	239	544	634	609	679
PR16U6060	16U	600	600	787	489	239	722	812	787	857
PR20U6060	20U	600	600	965	489	239	900	990	965	1035
PRX06U6060	06U	600	450+160	342	489	239	277	367	342	412
PRX09U6060	09U	600	450+160	476	489	239	411	501	476	546
PRX12U6060	12U	600	450+160	609	489	239	544	634	609	679
PRX16U6060	16U	600	450+160	787	489	239	722	812	787	857
PRX20U6060	20U	600	450+160	965	489	239	900	990	965	1035

5. TECHNICAL DRAWINGS

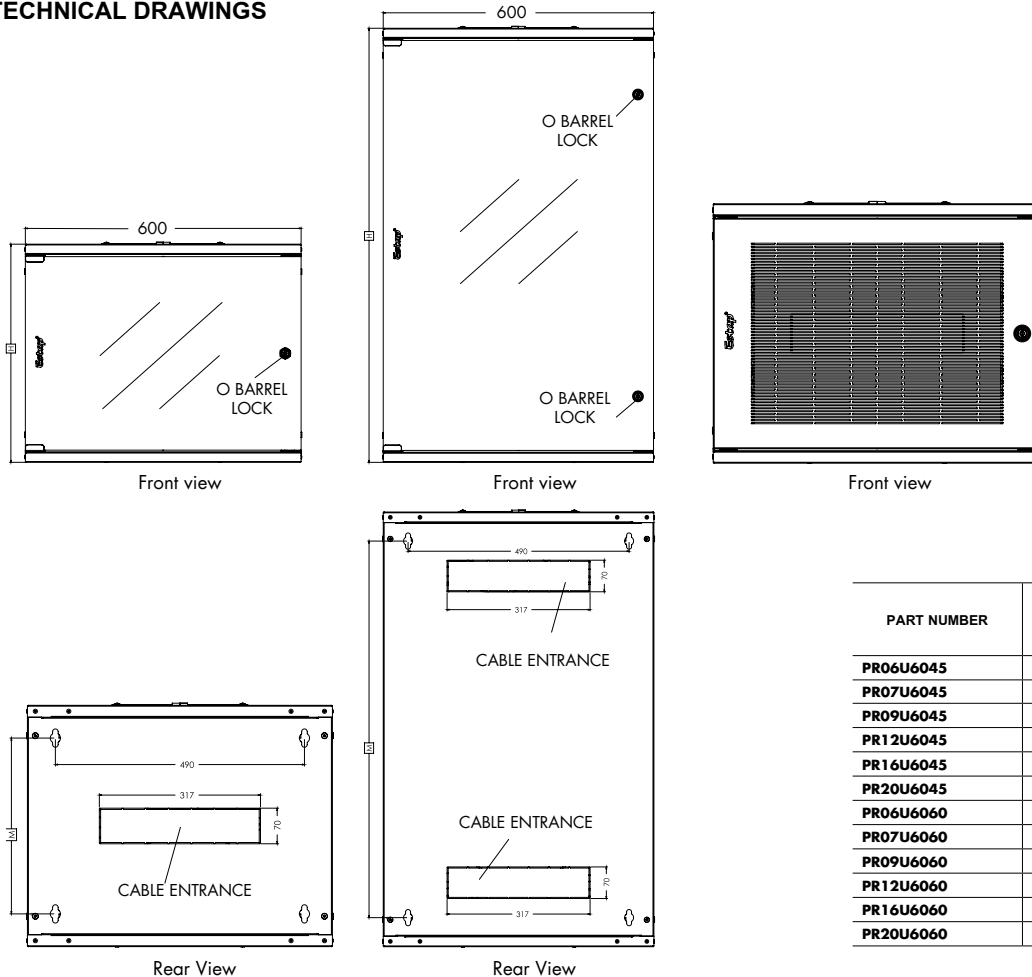

PART NUMBER	D	H	M	Lock Qty	Cable Entrances
PR06U6045	450	342	213	1	1
PR07U6045	450	386	257	1	1
PR09U6045	450	475	346	1	1
PR12U6045	450	608	480	2	1
PR16U6045	450	786	657	2	2
PR20U6045	450	964	835	2	2
PR06U6060	600	342	213	1	1
PR07U6060	600	386	257	1	1
PR09U6060	600	475	346	1	1
PR12U6060	600	608	480	2	1
PR16U6060	600	786	657	2	2
PR20U6060	600	964	835	2	2

H= Product Height

ProLine wall mounting cabinets

5. TECHNICAL DRAWINGS

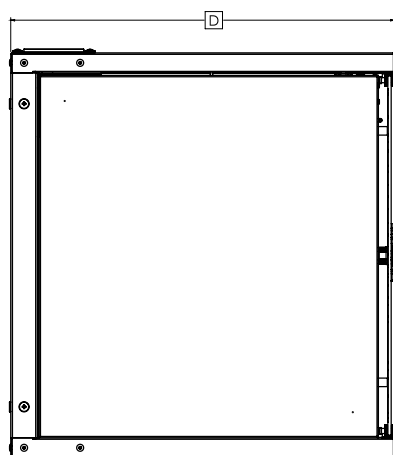

Side view

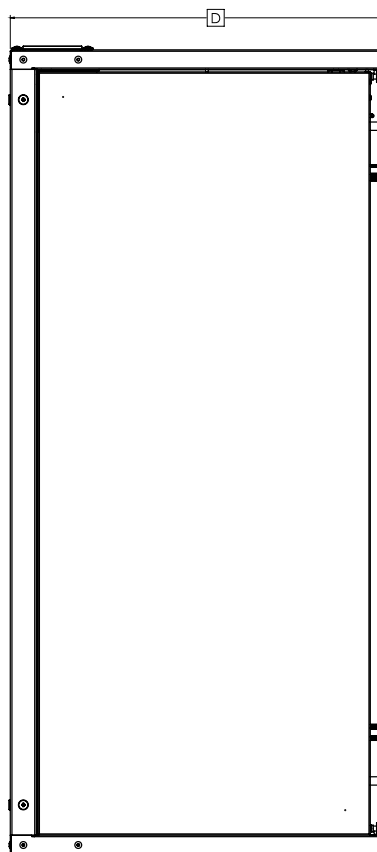

Side view

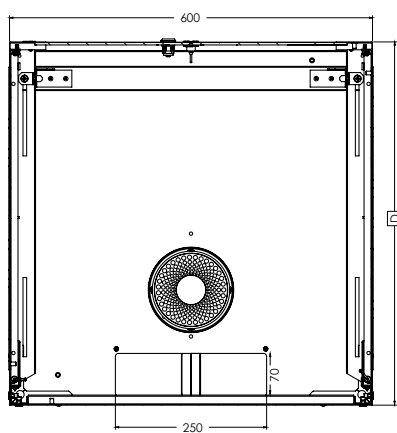

Top view

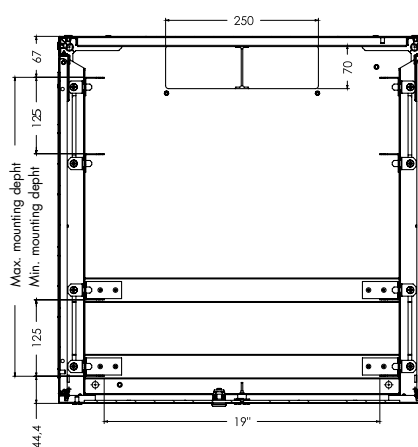

Bottom view

ProLine wall mounting cabinets

5. TECHNICAL DRAWINGS

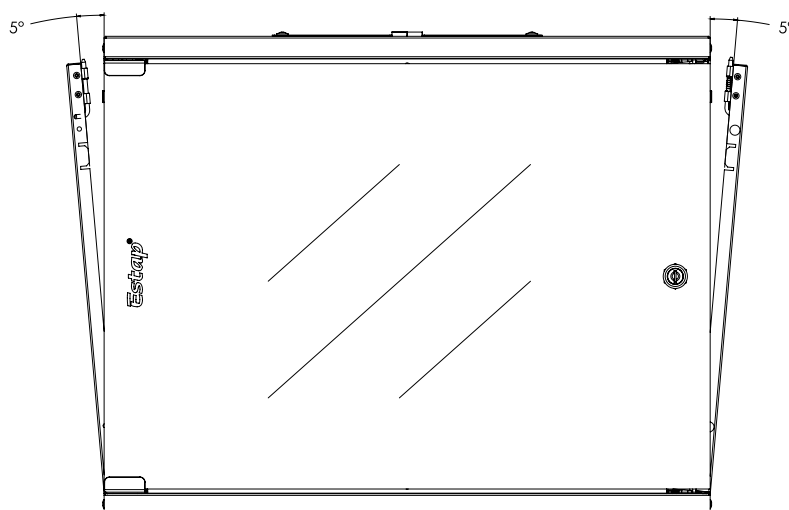
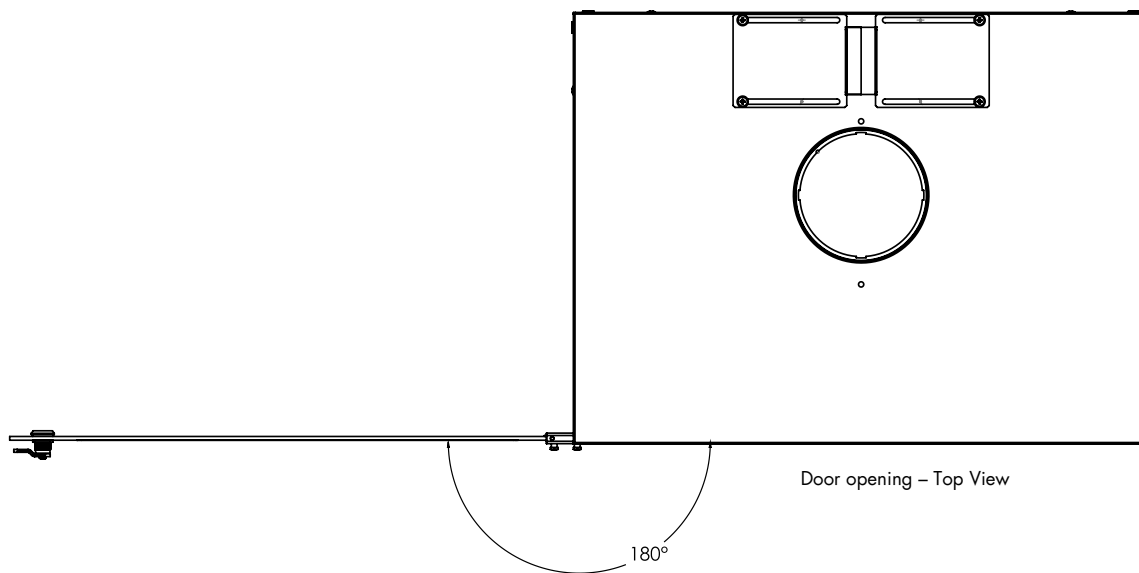

ProLine wall mounting cabinets

5. TECHNICAL DRAWINGS

Double Section Version Drawings

The 450 mm deep Proline series has a D = 160 mm, welded, wall mounted monoblock frame option which allows double section cabinet application. Thus, provides the possibility of increasing depth and offers access to the rear of the devices also.

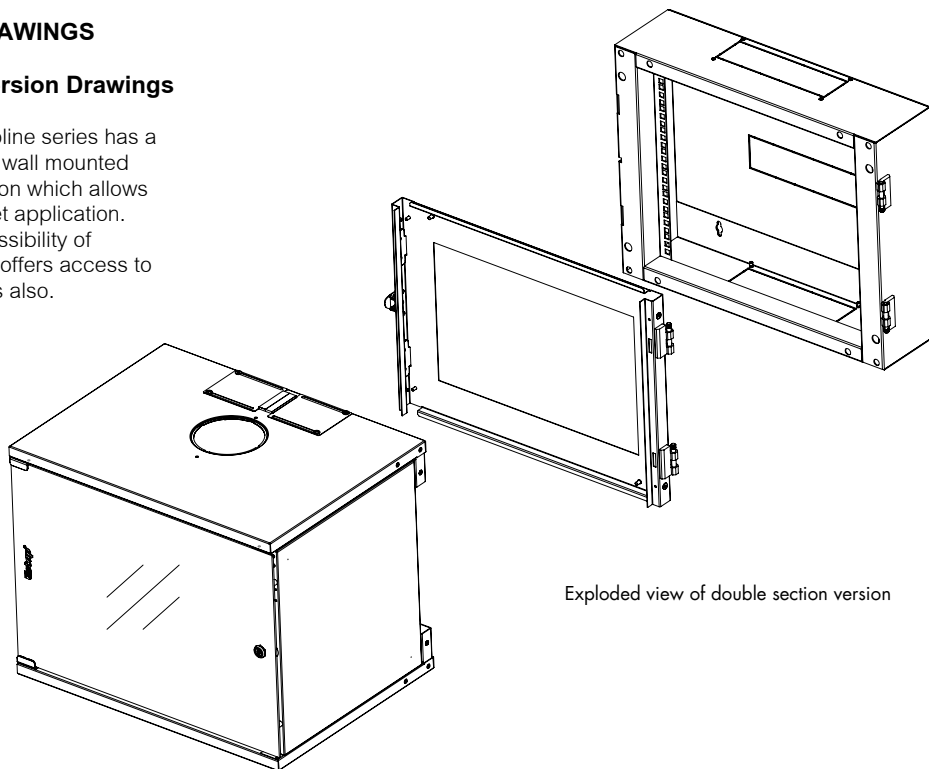

Exploded view of double section version

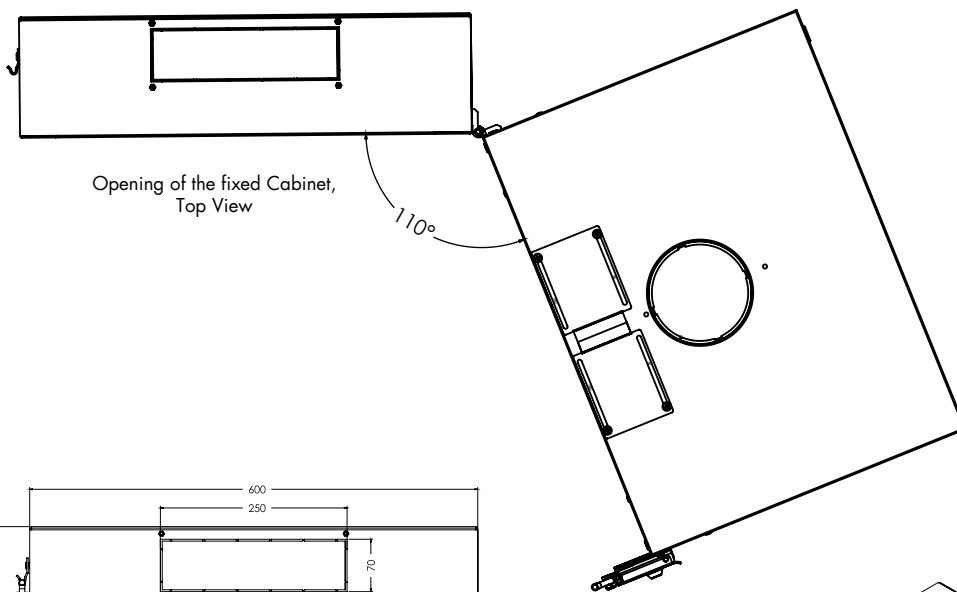

Opening of the fixed Cabinet, Top View

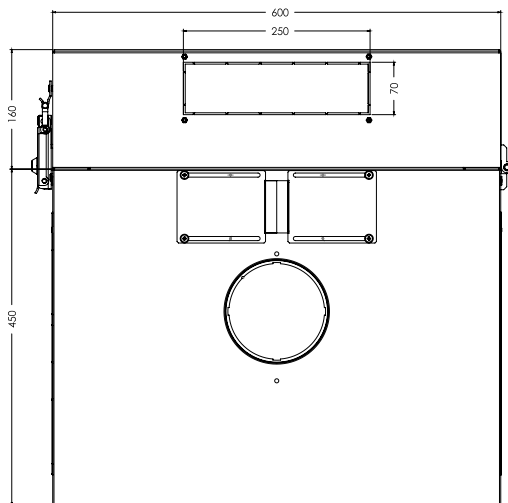

Top View

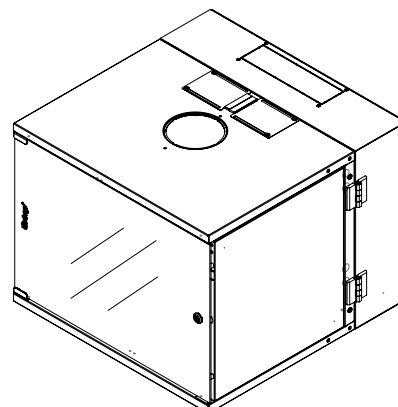

ISO view

ProLine wall mounting cabinets

6. ACCESSORIES

6.1. CASTER & LEVELLING FEET

- Castors are rotational type and can move any direction
- 2 ea. front are lockable
- Load capacity per castor:
Fixed: 50 kg
Moving: 25kg
- Load capacity per levelling feet: 250 kg.
- Levelling feet: Possible to adjust height of the feet from the floor.

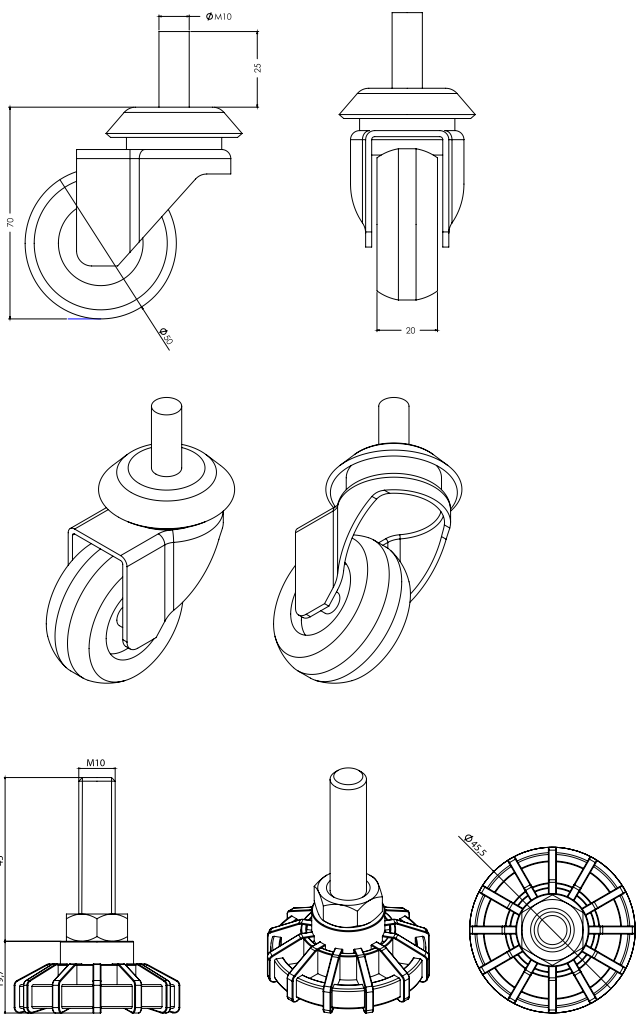

Product Code	WxDxH (mm)	W=600 D=450	W=600 D=600	W=600 D=450 +160
G22TKDUV	50x80x80	X	X	X
M11 PNY02	45xh (min. H=30 max H=45)	X	X	X
M11 PNY35	45xh (min. h=35 max H=50)	X	X	X
M11 PNY99	45xh (min. H=35 max H=90)	X	X	X

6.2. MOUNTING ANGLES

- Easy to assembly
- Notched for each U
- Material: Galvanize coated sheet steel

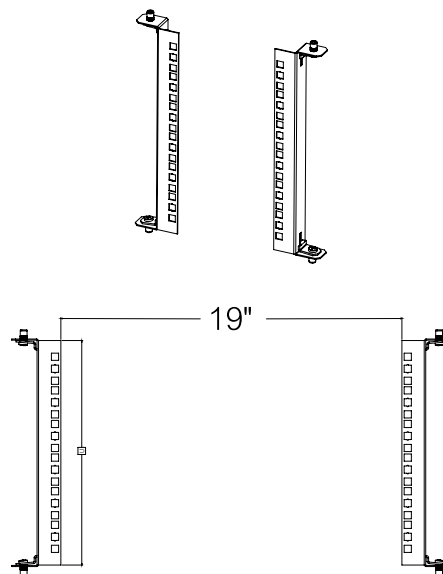

Product Code	U Height	W=600 D=450	W=600 D=600	W=600 D=450 +160
PRO CMD 06U	06U	X	X	X
PRO CMD 07U	07U	X	X	X
PRO CMD 09U	09U	X	X	X
PRO CMD 12U	12U	X	X	X
PRO CMD 16U	16U	X	X	X
PRO CMD 20U	20U	X	X	X

ProLine wall mounting cabinets

6.3. SHELF

6.3.1. RACK MOUNT SHELF

- 4 point, fixing directly to 19" mounting angles
- Vented
- Material: sheet steel
- Load carrying capacity : 20 kg
- Colour : RAL 9003 signal white
RAL 9005 black

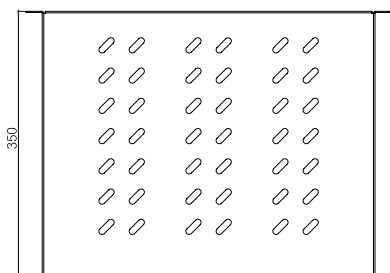
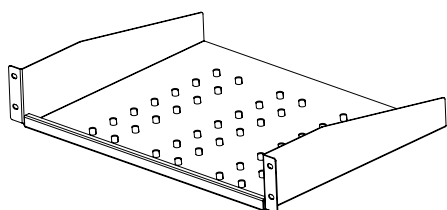

Product Code	WxDxH (mm)	W=600 D=450	W=600 D=600	W=600 D=450 +160
E44RAK20	483x200x44	X	X	X
E44RAK25	483x250x44	X	X	X
E44RAK30	483x300x44	X	X	X
E44RAK35	483x370x88	X	X	X
E44RAK40	483x400x44		X	

6.3.2. FIXED & SLIDING SHELVES

- Fixing points at the sides of rear and front 19" mounting angles
- Vented for air circulation
- Adjustable depth
- Material: sheet steel
- Load carrying capacity : 50 kg for fixed shelves
25 kg for sliding shelves
- Colour : RAL 9003 signalwhite
RAL 9005 black

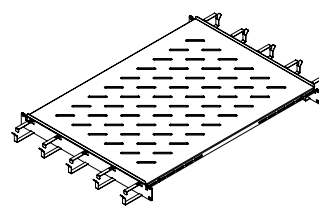
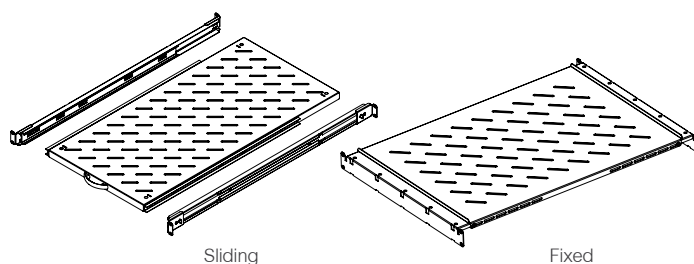

Fixed Shelf with horizontal cable organizer*

Product Code	WxDxH (mm)	W=600 D=450	W=600 D=600	W=600 D=450 +160
M44SBR60	465x345x30	X	X	X
M44HRK60	465x345x30	X	X	X
M44HRK60KM	483X425X44	X	X	X
M44SBR60KDM	483X425X44	X	X	X
M44KNCKDM	483X80X44	X	X	X

* Horizontal cable manager might be mounted at front or rear of the shelf. Could be ordered by using the product code: M44KNCKDM. This product is only suitable with M44SBR60KDM and M44HRK60KM. For 600 mm depth, it could be used at both sides. For 450 mm depth, it could be used either at front or at rear.

ProLine wall mounting cabinets

6.4. FAN

- Thermostat-air temperature controller
- Range: -10-+85 degree, below set point fan does not activate
- Above set point fan units start ventilation. Complete with inner wiring.
- Noise: 34-38 db
- A fan provides 2,33 / m3. Air removal,
- CFM:45-56
- Colour : RAL 9003 signal white
RAL 9005 black

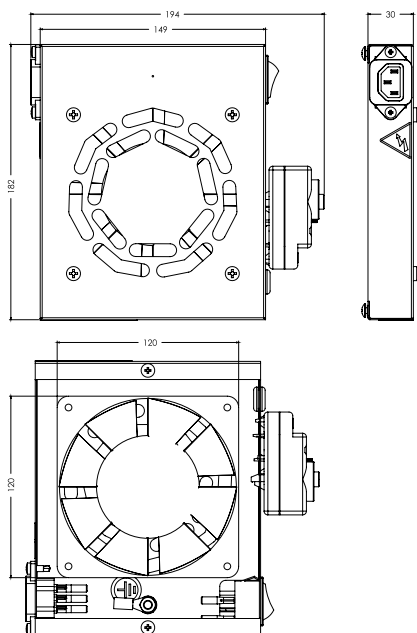

Product Code	WxDxH (mm)	W=600 D=450	W=600 D=600	W=600 D=450 +160
M346HV1FF	160x190x30	X	X	X
M346HV1FTF termostat	195x190x30	X	X	X
M346HV2FF	310x190x30	X	X	X
M346HV2FTF termostat	350x190x30	X	X	X

6.5. HORIZONTAL CABLE MANAGER

Metal;

- The range is suitable for all 19" applications.
- Sheet steel, easy to install and mount.
- Rings: 5 ea. cable hook
- Colour: RAL 9003 signal white
RAL 9005 black

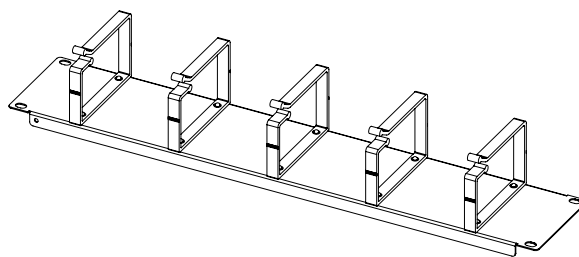

Standard

Product Code	WxDxH (mm)	W=600 D=450	W=600 D=600	W=600 D=450 +160
E44ORG1U	483x80x44	X	X	X
E44ORG2U	483x80x88	X	X	X
E44ORG1UN	483x80x44	X	X	X
E44ORG1F	483x100x22	X	X	X
E44ORG2F	483x124x44	X	X	X
E44ORG2F-BN	483x10x44	X	X	X

ProLine wall mounting cabinets

6.6. LED LIGHT

- Different dimensions.
- 2 different connection apparatus to connect units.
- Effective and powerful lightning.
- Light and strong structure.
- Economical solution.

Dimension : L500/L800/L1000*25*13,5 mm

Input : DC12V
 Emitting Colour : White (5000-6500K)
 Ra : 70-80
 Power : 5W / 8,5W / 10,5W
 Material : Alu+Glass
 Luminous Flux : 360~450lm
 Adaptor Capacity : 36W
 Other Length : 300 mm, 500 mm, 800 mm, 1000 mm

Quick Details

Light Source : LED
 Item Type : Cabinet Lights
 LED Light Source : SMD 3014
 Install Style : Wall Mounted
 Shade Type : PC
 Shade Direction : Down
 Input Voltage(V) : DC12V
 Lamp Power(W) : 5W / 8,5W / 10,5W
 Lamp Luminous Flux(lm) : 350-450LM
 Lamp Luminous Efficiency(lm/w) : 85
 CRI (Ra>) : 75
 Color Temperature (CCT) : Pure White
 Certification : CE, EMC, RoHS, UL
 Emitting Color : White
 Color : Cold White
 Life : 30,000h
 Material : PC+Alu
 IP grade : IP 20

Product Code	WxDxH (mm)	W=600 D=450	W=600 D=600	W=600 D=450 +160
MAYDNLED-IRM	300X30X10	X	X	X

6.7. CABLE ENTRY PART

All ProLine products consists single cable entry part inside the cabinet along with the order. According to cable entry, it could be mounted on top or on bottom. If additional one needed, it might be ordered as an accessory.

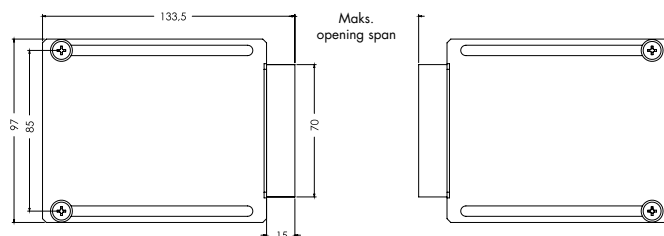
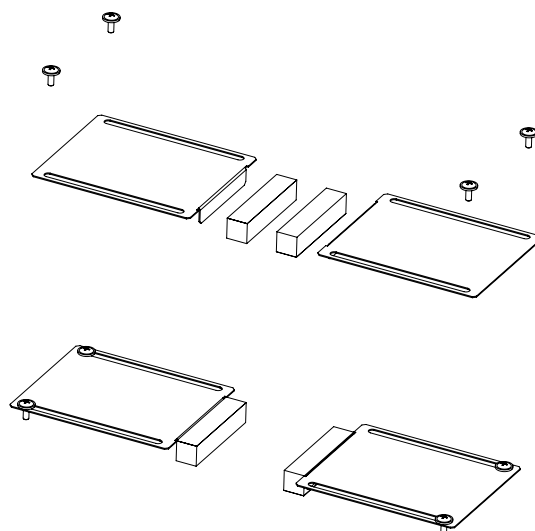

Product Code	Dimension (mm)
M346DAS	200X70

ProLine wall mounting cabinets

6.8. HANGING KIT

In case of weak walls or, not any suitable place on the wall, ProLine could be mounted on the ceiling with this hanging kit.

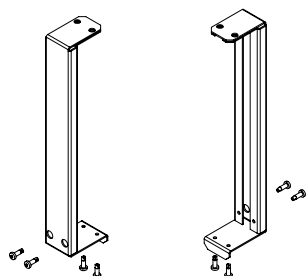
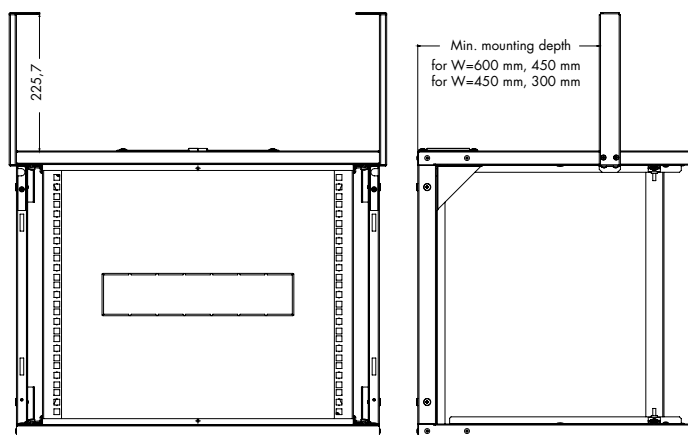
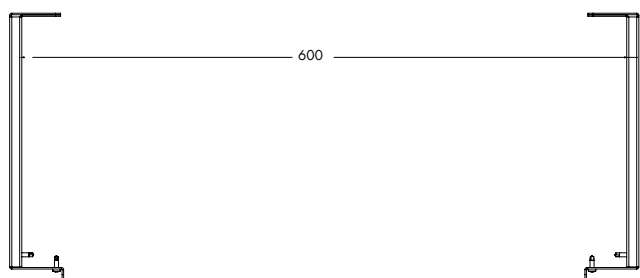
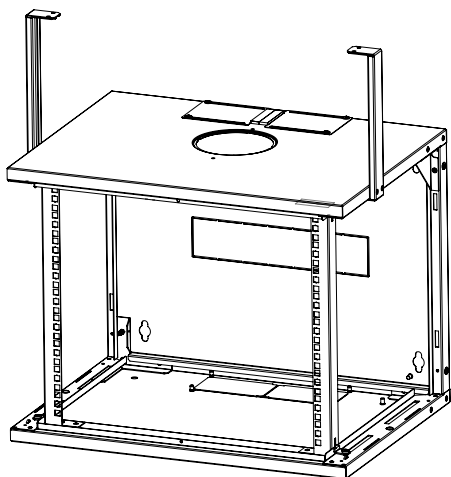

6.9. BLANK PANEL

Blank panels are used to close empty positions in the cabinet.

- 19"
- Material: Sheet steel
- Colour: RAL 9003 signal white
RAL 9005 black

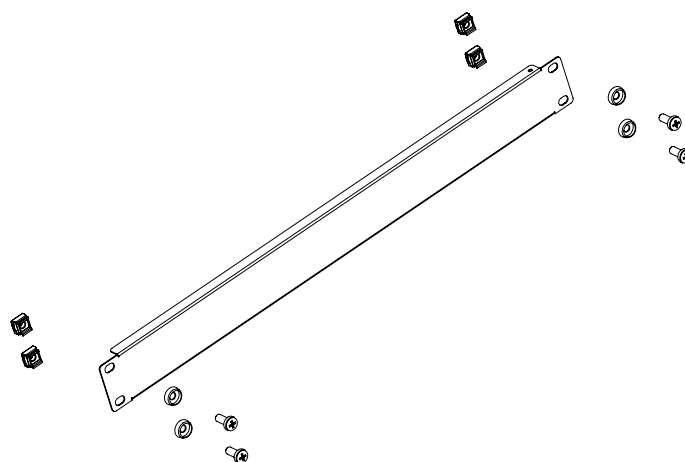
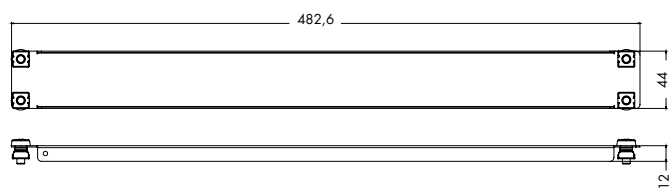

ProLine wall mounting cabinets

6.10. PDU

Estep offers a wide PDU product range

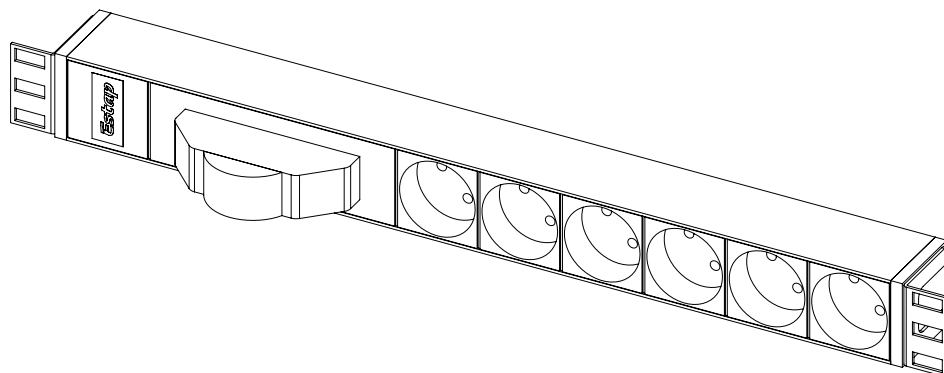

Part number	Product definition	WxDxH (mm)
M443AL	3xDIN49440 Socket Schuko PDU, 19", 1U, aluminium profile frame, 1x16A MCB, 4000 Watt, 250 Vac, 3x1.5 mm ² , 3 m cord with DIN 49441 plug, CE mark	483 (19") x 44.4x44.4
M446AL	6xDIN49440 Socket Schuko PDU, 19", 1U, aluminium profile frame, 1x16A MCB, 4000 Watt, 250 Vac, 3x1.5 mm ² , 3 m cord with DIN 49441 plug, CE mark	483 (19") x 44.4x 44.4
M446ALUK	6xBS1363 UK Socket PDU, 19", 1U, aluminium profile frame, 16A On/Off Lighted Switch, 4000 Watt, 250 Vac, 3x1.5 mm ² , 3 m cord with 13A BS1363 plug, CE mark	483 (19") x 44.4x44.4
M446ALD	6xDIN49440 Socket Schuko PDU, double circuit (3+3) 19" with aluminium profile frame, 2x16A MCB, 4000 Watt, 250 Vac, 3x1.5 mm ² , 2,5 m cord with DIN 49441 plug	483 (19") x 44.4x44.4
M446STD	6xDIN49440 Socket Schuko PDU, 19", 1U, aluminium profile frame, 16A On/Off Lighted Switch, 4000 Watt, 250V AC, 3x1.5 mm ² , 3 m cord with DIN 49441 plug, CE mark	483 (19") x 44.4x 44.4
M446ALSP	6xDIN49440 Socket Schuko Surge Arrest PDU, 19", 1U, aluminium profile frame, 16A On/Off Lighted Switch, 4000 Watt, 250 Vac, 3x1.5 mm ² , 3 m cord with DIN 49441 plug, CE mark	483 (19") x 44.4x 44.4
M446ALIEC	6xIEC 320 C13 Socket PDU, 19", aluminium profile frame, 1x16A MCB, 4000 Watt, 250 Vac, IEC 320 C14 plug	483 (19") x 44.4x 44.4
M446ALDIEC	6xIEC 320 C13 Socket PDU, double circuit (3+3), 19" aluminium profile frame, 1x16A MCB, 4000 Watt, 250V AC, IEC 320 C14 plug	483 (19") x 44.4x 44.4
M449ALC	9xDIN49440 Socket Schuko PDU, 19" 2U, aluminium profile frame, 1x16A MCB, 4000 Watt, 250V AC, 3x1.5 mm ² , 3m cord with DIN 49441 plug, CE mark	483 (19") x 44.4x 88.8
M449ALCIEC	9xIEC 320 C13 Socket PDU, 19", aluminium profile frame, 1x16A MCB, 4000 Watt, 250 Vac, IEC 320 C14 plug	483 (19") x 44.4x 44.4
M449ALCD	9xDIN49440 Socket Schuko PDU, double circuit (4+5), 19", with aluminium profile frame, 2x16A MCB, 4000 Watt, 250 Vac, 3x1.5 mm ² , 2,5 m cord with DIN 49441 plug	483(19") x44.4x120
M449ALDIEC	9xIEC 320 C13 Socket PDU, double circuit (4+5), 19", aluminium profile frame, 1x16A MCB, 4000 Watt, 250 Vac, IEC 320 C14 plug	483(19") x44.4x120
M446ALIECAMP	6xIEC 320 C13 Socket PDU with Ampermeter Display, 19", 1U, aluminium profile frame, 1x16A MCB, 4000 Watt, 250 Vac, 3x2.5 mm ² , 3 m cord with IEC60309 plug (16A 2P+E), CE mark	483 (19") x44.4x44.4

ProLine wall mounting cabinets

7. TECHNICAL SPECIFICATIONS

7.1. TESTS AND CERTIFICATIONS

Environment

EN61587-1 / 4.2, IEC60068-2, IEC60068-2-2, IEC60068-2-30, IEC60917 and IEC60297

Industrial Environment

EN61587-1 / 4.3, IEC60068-2-42, IEC60068-2-43 and IEC60068-2-49, IEC60068-2-1, IEC60917 and IEC60297

Static mechanical structure load test

EN61587-1 / 5.2.1, IEC60917 and IEC60297

Static mechanical structure stability

EN61587-1 / 5.2.2, IEC60917 and IEC60297

Dynamic load, vibration and mechanical stroke

EN61587-1 / 5.3.1, EN61587- / 5.3.3, IEC60917, C60297, IEC62208

Grounding continuity

EN61587-1 / 6.2, IEC60917 and IEC60297

Fire and flame resistance

EN61587-1 / 6.3, IEC60917 and IEC60297

Corrosion

ISO9227 and ASTM B 117-85

IP protection degree

IP20 according to EN61587-1, IEC 60529

PURCHASED PRODUCT CERTIFICATIONS

Sheet steel

DIN EN 10130 – 99 Ereğli DC-01 6112, 7122, RoHS

Electrostatic powder coating

ISO 9001, ISO 2178, ISO 2813, ISO 6272, ISO 8130-5, ISO 8130-3, RoHS

Fan

ISO 9001, CE (89/336/EEC EMC, 73/23/EEC LVD), RoHS

Glass

ISO 9001, EN 12150 – 1: 2000 tempered and secure

Fixings

DIN 7985, DIN 965, DIN 7981, DIN 934, DIN 985, DIN 933, RoHS

Castors

TS EN 12530, TS EN 12532, RoHS

Lock

DIN 1743, DIN 53571, RoHS

7.2 KEY FEATURES

The upper and lower frame, has a unwelded, monoblock and internal latching design to increase the power of the resistance of the cabinet structure. Hence there is no use of carrier profile, the cabinet provides ease of access and intervention. Proline provides a carrying capacity of 200 kg in the use of free-standing, and 50 kg of wall-mounted usage according to the engineering calculations.

Front door; according to the standard EN 12150-1:2000, complete adhesive and glass structure. Glass; tempered, anti-static, secure, decorative serigrafil smoked and 4 mm thick. ProLine series front door is lockable, removable and 180 degrees openable. In addition, perforated metal front door options are also available.

Microjoint cable entries are on the top and bottom chassis. Every cabinet has 1 sliding cable entrance cover in the cabinet. Thus, the desired cable entry is convertible to a sliding cable entrance. As standard, 1 Fan mounting hole on top chassis is conducive to optimum cooling which does not causes any "U" loss in case of fan installation.

The 450 mm depth ProLine series has a D = 160 mm, welded, wallmounted monoblock frame option which allows double section cabinet application. Thus, provides the possibility of increasing depth and offers access to the rear of the devices also.

Standard rear panel are mounted with 4 screws tightened mechanically. In addition, if needed to route the cables from the wall to the cabinet, a microjoint cable input available on the back. 6U, 7U and 9U models has 1, 12U, 16U and 20U models have 2 cable entries. ProLine series' all cable entries are wide enough to allow removing fiber patch panels from the interior.

The side panels has an openable (from inside, after opening the front door of the cabinet), lockable and removable structure. Thus, provides extra security, but also has a highly aesthetic appearance. 19" mounting angles 2 on front, is included as part of the cabinet interior configuration. Optionally 2 pieces can be mounted to the rear.

ProLine wall mounting cabinets are usable as free standing cabinets with castor and leveling feet set up options.

The Cabinet complies with EN 61587-1, IEC 60917, IEC 60297 standards, and are RoHS compliant, GOST and TSE certified. Cabinets are manufactured at Estap factory which has ISO 9001 Quality Management System and ISO 14001: 2004 Environmental Management System showing our commitment to the environment.

ProLine wall mounting cabinets

7.3 TECHNICAL SPECIFICATIONS

Customs tariff number

With Accessories: 853710100000 / 853710990019
Without accessories: 853810100000

Shipping structure

Assembled / Dismantled

Mounting Surface

Wall mounted

Load carrying capacity (kg)

50kg in the use of wall-mounted
200kg in the use of free-standing (rear mounting angles and with four-point fixed shelves)

Certification on product

TSE, Gost, UL

Surface finish

Electrostatic powder coated surface treatment; 60-120 micron and tested according IEC 60068-2-1, 2-2, 2-30,2-42.

STANDARD PRODUCT**Standard colors**

RAL 9003 Signal white RAL 9005 Black

IP Protection Class

IP20

FRONT DOOR

Tempered glass

Glass

Smoked, tempered, safe and decorative
Screen printing, 4 mm thick complete glass structure.

Front door structure

Single opening door

Front door opening angle

180 degrees

Front door lock

"O" type barrel lock (12U and more U height cabinets contains 2 for safety)

Adhesive material

High density polyurethane DIN 53479, DIN 53505

SIDE PANEL

Solid metal, 0.8 mm, 2 pcs. (left and right)

Side panel structure

Openable, lockable, removable

Side Panel lock

Single point locked

REAR PANEL

Solid metal , 1.2 mm

Rear panel structure

Mechanically locked from outside with 4 screws

FRAME STRUCTURE**Top chassis structure**

Mounting hole for a single fan (dual-fan applicable if required)

Upper and lower chassis structure

Completely modular, seamless

Rear corner profiles

Solid metal, 1.2 mm

Corner profile structure

Firmly fixed to the upper and lower chassis unit 6 times folded

INTERNAL PARTS**19" Mounting Angles**

Solid metal, 1.5 mm

1 fold,

"U" marking notched. 4 pcs. be mountable(2 pcs. rear and 2 pcs. front)

19" pre-configuration.

Galvanized